



# Owner's Manual

RAPID/X6

# CONTENTS

Carefully read these operating and installation instructions and keep them safe. Should this system change hands, pass these instructions to the subsequent owner. Additionally, provide this document to any trained contractor for servicing proposes.

Symbols used in these instructions:



Important information and tips.



Important information regarding flammable materials.



Warnings about possible dangers



Australian Standard  
AS/NZS2712:2007  
SMK40937  
SAI Global



Water Mark  
AS 3498 Lic WMK 26182

1.0	SAFETY WARNINGS.....	2
2.0	PARTS & CONSTRUCTION SCHEMATICS.....	3
2.1	RAPID/X6 DIMENSIONS.....	3
2.2	RAPID/X6 SCHEMATICS.....	4
3.0	INSTALLATION INSTRUCTIONS.....	5
3.1	DELIVERY.....	5
3.2	BASE.....	6
3.3	AIR FLOW.....	7
3.4	POWER SUPPLY TARRIFS.....	8
3.5	NOISE CONSIDERATIONS.....	8
4.0	PLUMBING SCHEMATICS.....	9
4.1	RAPID/X6 CONNECTION DIMENSIONS AND COMPONENTS.....	9
5.0	PLUMBING INSTALLATION.....	10
5.1	PLUMBING CONNECTIONS.....	10
6.0	ELECTRICAL CONNECTION.....	13
6.1	ELECTRICAL SCHEMATICS.....	13
6.2	PRE-CONNECTION & REGULATIONS.....	14
6.3	HARDWIRING THE SYSTEM.....	14
7.0	COMISSIONG THE SYSTEM.....	15
7.1	PRE-START PROCEDURES & CHECKS.....	15
8.0	OPERATION PANEL INSTRUCTIONS.....	17
8.1	ACCESSING THE DISPLAY PANEL.....	17
8.2	CONTROL INTERFACE.....	18
8.3	INTERFACE ICONS.....	19
8.4	UNLOCKING & TURNING THE SYSTEM ON.....	20
8.5	SETTING THE TIMERS.....	20
8.6	SETTING THE CLOCK.....	22
8.7	ERROR HANDLING.....	23
9.0	TROUBLE SHOOTING.....	24
10.0	FAQ.....	26
11.0	WARRANTY - AUSTRALIA ONLY.....	27

## 1.0 SAFETY WARNINGS



### INSTALLATION & OPERATION

- For outdoor use only.
- DO NOT install or operate this system before reading the manufacturer's instructions.
- This appliance must be installed, commissioned and serviced by an authorized person in accordance with all applicable local rules and regulations.
- Removing access covers and or water heating system components will expose 240V wiring and MUST only be removed by an authorized person.
- The unit is rated at 10 amps (2 core and earth) so the power mains supplying the unit must have a 10-amp minimum double pole circuit breaker fitted.
- If the systems power supply cord is damaged, it MUST BE replaced by an authorised person in order to avoid a hazard. Take care not to touch the power connections or plugs with wet hands.
- This appliance is not intended for use by persons (including children) with reduced physical, sensory or mental capabilities, or lack of experience and knowledge, unless they have been given supervision or instruction concerning use of the appliance by a person responsible for their safety.
- Children should be supervised to ensure they DO NOT play with the appliance.
- For continued safety of this appliance it must be installed, operated and maintained in accordance with the manufacturer's instructions.
- Care should be taken not to touch the pipe work as it may be HOT!
- DO NOT place articles on or against this appliance.
- DO NOT store chemicals or flammable materials near this appliance.
- DO NOT operate with collectors or covers removed from this appliance.
- DO NOT activate heat pump unless cylinder is full of water.
- NEVER use a flammable spray such as hair spray, paint, etc near this unit as this may cause a fire.



### INSTALLATION & OPERATION

- This appliance uses R290 (propane) refrigerant, which is a flammable gas class 3 according to AS 1677 and must be handled by a refrigeration mechanic with appropriate Australian refrigerant handling license.
- WARNING Risk of fire/flammable material. If the refrigerant is leaked, together with an external ignition source, there is a possibility of ignition.
- DO NOT store chemicals or flammable materials near this appliance.
- NEVER use a flammable spray such as hair spray, paint, etc near this unit as this may cause a fire.

## 2.0 PARTS & CONSTRUCTION SCHEMATICS

### 2.1 RAPID/X6 DIMENSIONS

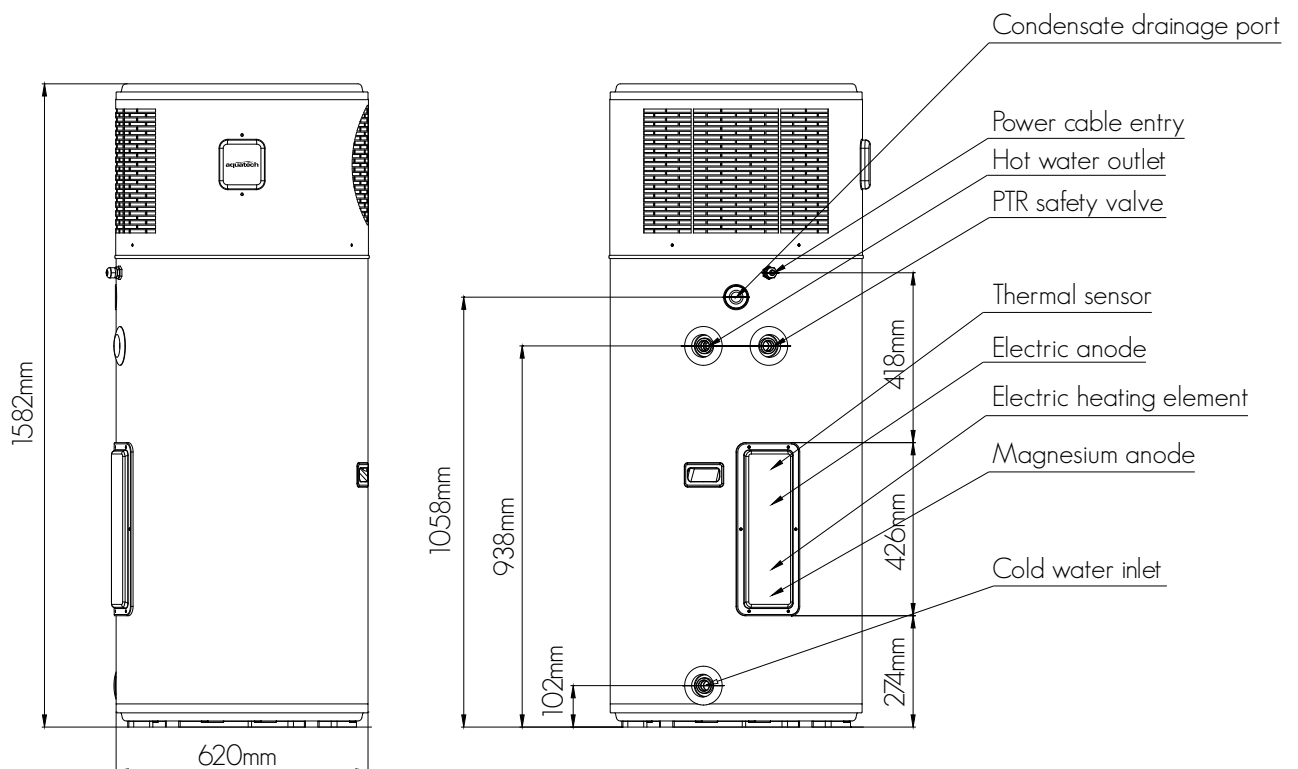

The RAPID/X6 use a R290 (propane) refrigerant which is a flammable gas class 3 according to AS 1677 and must be handled by a refrigeration mechanic with an appropriate Australian refrigerant handling license.



Warning - Risk of fire due to flammable material. If the refrigerant is leaked and there is an external ignition source, there is a possibility of ignition.

## 2.2 RAPID/X6 SCHEMATICS

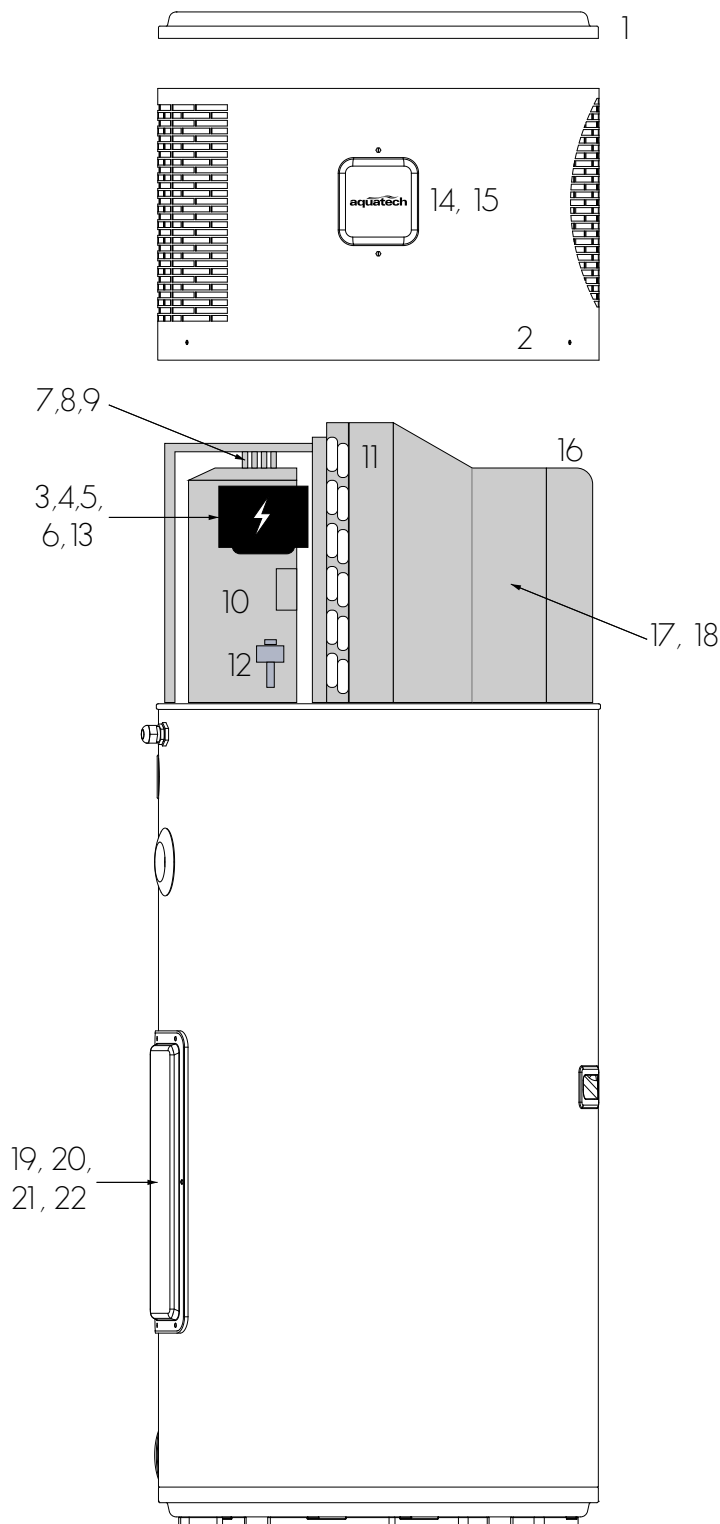

1. Top Lid
- 2.. Upper Cover
3. Electronic Main Board
4. Electronic Anode Transformer
5. Fan Capacitor
6. AC to DC Transformer
7. Compressor Run Capacitor
8. Compressor Starter Capcitor
9. Compressor Wiring Harness
10. Compressor
11. Evaporator
12. Electronic TX Valve
13. 5V Sensors
14. Display Cover
15. Screen board
16. Foam Fan Cover
17. Fan Blade
18. Fan Motor
19. Thermal Sensor
20. Electric anode
21. Electric Heater
22. Magnesium anode

## 3.0 INSTALLATION INSTRUCTIONS

All Aquatech heat pumps are designed for installation by a licensed plumber in accordance with standards set out in AS/NZS 3500.2 "National Plumbing and Drainage Code Hot Water Supply Systems - Acceptable Solutions".

### 3.1 DELIVERY

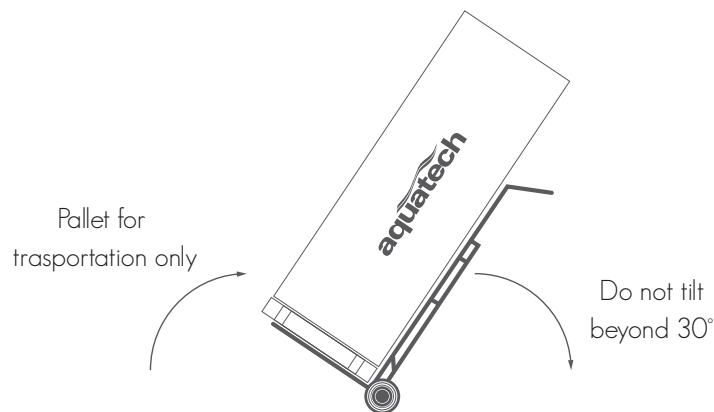

- Aquatech heat pumps must be stored and transported in a near vertical position at all times with a tilt ratio of no more than 30°. Transporting or storing the unit in a horizontal position will void warranty.
- The system should always be transported in its packaging.
- The weight of the package system is 125kg (108kg unpacked). The system must be handled by two people at all times to avoid unnecessary strain and damage.
- Please note the outer casing of the unit is susceptible to denting and damage. Care and consideration should be taken into account when moving the unit as any marks caused by inappropriate handling are not deemed as defects and are not covered under warranty.

The RAPID X6 uses a flammable gas, therefore:



- The appliance should not be stored or transported in an area with an ignition source (e.g. open flame).
- Do not pierce or burn the appliance.
- Be aware that the refrigerant may not cause an odour.
- Compliance with AS/NZS 5601 must be observed while storing the appliance.



National and state regulations exist for the storage, transportation and handling of hazardous goods including flammable gasses. The maximum number of and configuration of the equipment permitted to be transported or stored together will be determined by the appliance regulations.

## 3.2 BASE

The following should be observed when selecting a base for a RAPID/X6:

- The unit should be installed on a concrete plinth or stable structure capable of sustaining weights in excess of 315kg. The supporting structure must not shift over time (due to water drainage etc.). A concrete base of at least 50mm thick or a well-seasoned hardwood slat at least 25mm is required. If a concrete base paver is being used, a minimum dimension of 600mm x 600mm is required.
- Please ensure that all four feet are supported by the base being used otherwise warranties may be voided.
- Proper drainage should be observed for any overflow in accordance with AS/NZS 3500.2.
- When installed the Aquatech unit must be completely vertical and level as to ensure that condensate can be properly drained. If the system is installed at a level with a tilt of more than 3 degrees, warranties may be voided.
- If property damage can occur due to water leakage, a safe tray (overflow tray) must be installed.

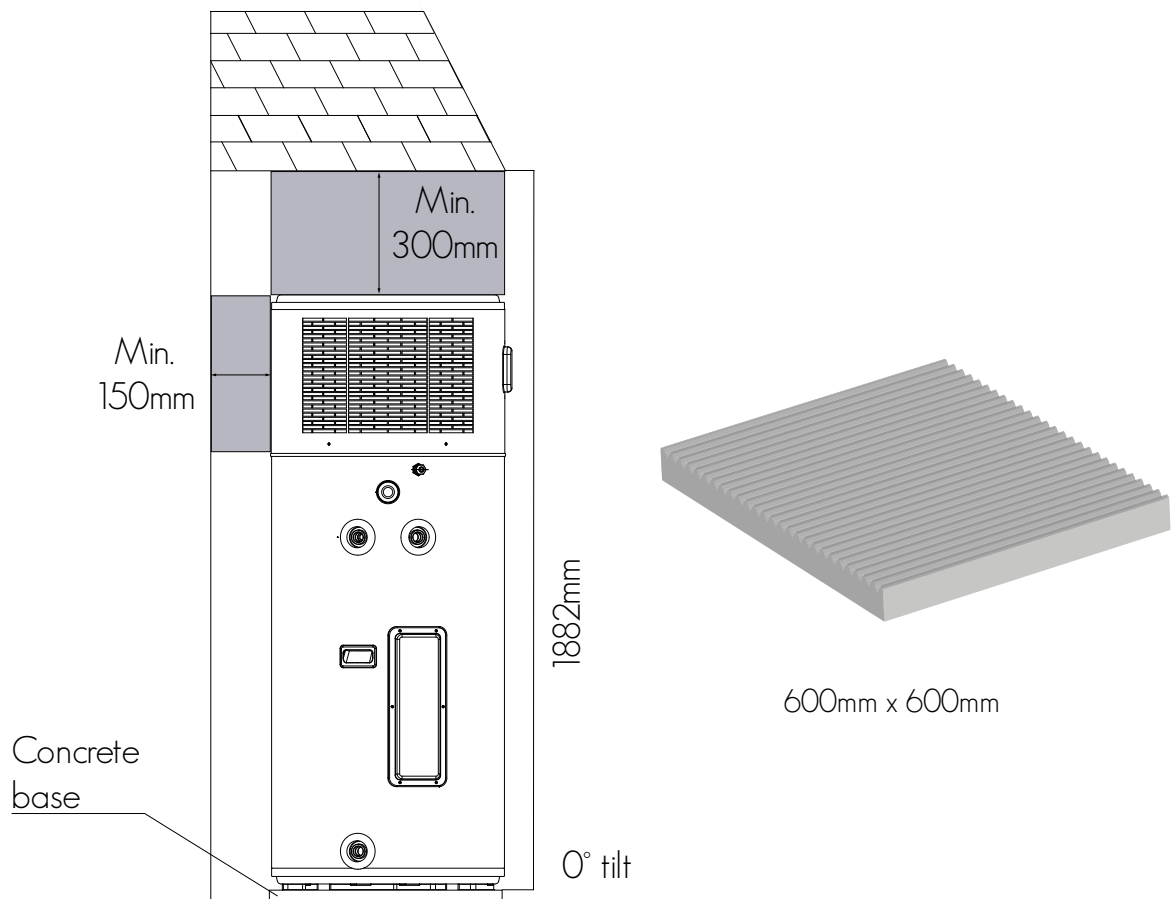

Figure 1: Side profile installation requirements and an example concrete base.

### 3.3 AIR FLOW

- This unit is designed for external operation only and requires a continuous supply of air to operate efficiently.
- Avoid installation in areas where falling debris such as leaves is prevalent, as this may result in air vents being blocked or the unit being damaged.
- Avoid placing the system in locations with multiple walls or structures (See Figure 1 & 2). Always maintain optimum perimeter from all structures.
- If installed under fixtures or home eaves, there must be a minimum 300mm clearance between the top of the unit, 600mm on the right-hand side of the system (when facing unit) and 150mm on the left-hand side of the system (when facing system) (see section 2.3 AIR FLOW). The Aquatech must be installed a minimum of 150mm off your home's wall so that the entire unit can be accessed during any servicing work as well as to prevent circulation of cold air (see section 2.3 AIR FLOW). If the system cannot be properly serviced due to the system being installed outside of these specifications, the owner will be liable for the associated plumbing costs of draining and moving the system.
- The system should be installed so that the control interface is accessible to users and that there is clear access to the electrical panel at the back of the system.

Where incorrect installation has occurred, warranties may be void or additional charges may be required to ensure that the system is compliant and/or serviceable.

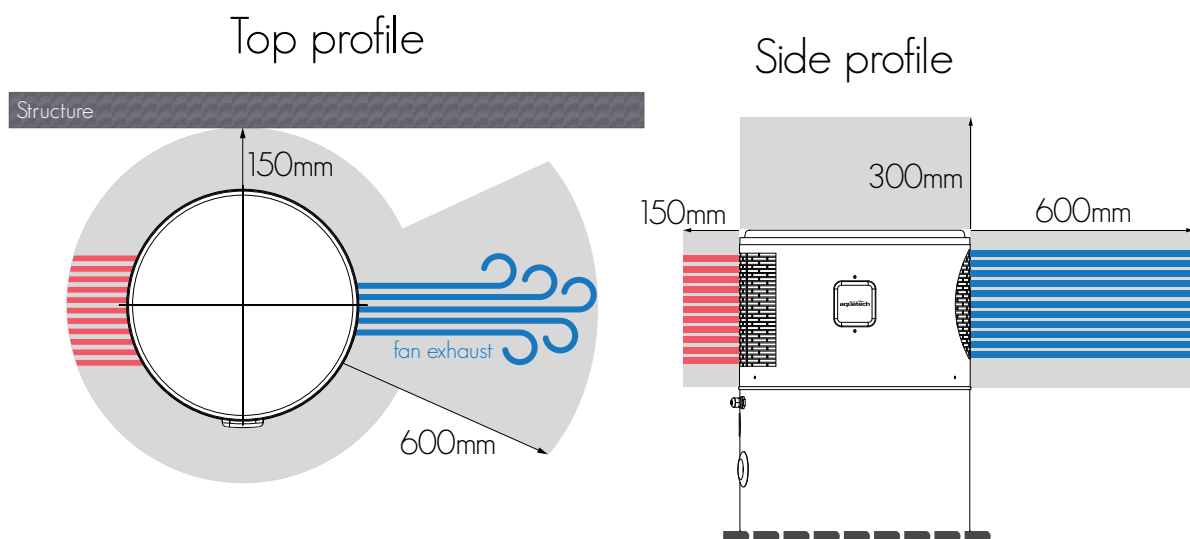

Figure 2: Front profile of RAPID/X6 installation requirements.



RAPID/X6 systems are designed for external use only with a minimum of 20m<sup>3</sup> of unobstructed space surrounding the unit.



Please ensure that the installation location complies with the requirements of AS/NZS 5601 with regards to a heat pump containing a flammable refrigerant.



The electrical access panel and display panels should always be accessible.



### 3.4 POWER SUPPLY TARRIFS

Electricity companies across the states and territories of Australia have different usage rates, naming conventions and even available tariffs. Always be sure to check with your electricity provider that the system is connected to a compatible tariff.

#### COMPATIBLE TARIFFS:

- **Continuous tariff** - 24 hours a day.  
The Continuous tariff is what every household connected to the grid has as a minimum. If you would like to utilize a Solar PV system to run your Aquatech system on, this is usually the only tariff available to do so.
- **Shoulder tariff** - Min. 16 hours a day  
The Shoulder tariff typically runs during the day and will turn off at night. The cost per kWh is cheaper than a Continuous tariff. If your household has more than 4 people or are heavy users of hot water, we recommend placing the Aquatech system on a Continuous tariff instead.

#### INCOMPATIBLE TARIFFS:

- **Off-Peak/Night time tariff** - Min. 8 hours a day  
Aquatech systems are not compatible on Off-Peak/Night time tariffs.

Aquatech systems should not to be installed on an Off-Peak 8-10 hour supply tariff for the following reasons:

- Aquatech heat pumps work up to 25% more efficiently during the daytime when ambient air temperatures are at their highest. The cost of running the system is actually cheaper running on a Shoulder tariff or Continuous tariff as the system will take considerably longer to heat on an Off-Peak tariff.
- You may run out of hot water. If your system needs to heat twice a day, it will unlikely be able to do some on an Off-Peak tariff.
- Servicing cannot be done outside business hours (the only hours an Off-Peak tariff has power). If the system needs to be changed onto another tariff, the Aquatech owner will be liable for the associated electrical costs.

If you would like further information regarding tariffs, we recommend speaking with your electrician and energy service provider before your Aquatech is installed.

### 3.5 NOISE CONSIDERATIONS

All customers are recommend to set the system onto TIMER Mode to utilize the in-built timer function. Setting the in-built timers to have the system run during the day is far more efficient and will also limit any potential disturbances. The TIMER mode's factory setting limits system operating time between 09:00-18:00, which is compliant with EPA prohibited operating hours.



Do not install less than 3 metres from a neighbour's window or door (aside from garage door or shed).



If you are experiencing noise issues with your Aquatech system, please contact Aquatech directly. There are mean to mitigate the sound produced when the system is operational.

## 4.0 PLUMBING SCHEMATICS



The following instructions and schematics have taken into account standards AS4324, AS4020, AS1056.1, AS/NZS2712, AS/NZ3350.240/30/30.2, AS3498 and represents an optimum installation procedure for this unit however to ensure minimum requirements are met all local

### 4.1 RAPID/X6 CONNECTION DIMENSIONS AND COMPONENTS

1. Cold Water supply outlet  
(G 3/4" female thread)
2. Hot Water Outlet  
(G 3/4" female thread)
3. Condensing drainage Elbow\*
4. P&T Relief Valve\*  
(G 1/2" female) (850kPa)
5. Electrical Cable
6. Tempering Valve  
(high performance recommended)
7. Expansion Control Valve (ECV)  
(if required by council 700kPa)
8. Pressure Reduction Valve  
(500kPa)
9. Non-return/Isolation Valve
10. Isolation Switch  
(Hard wired into 10 Amp circuit)

\* Supplied with system

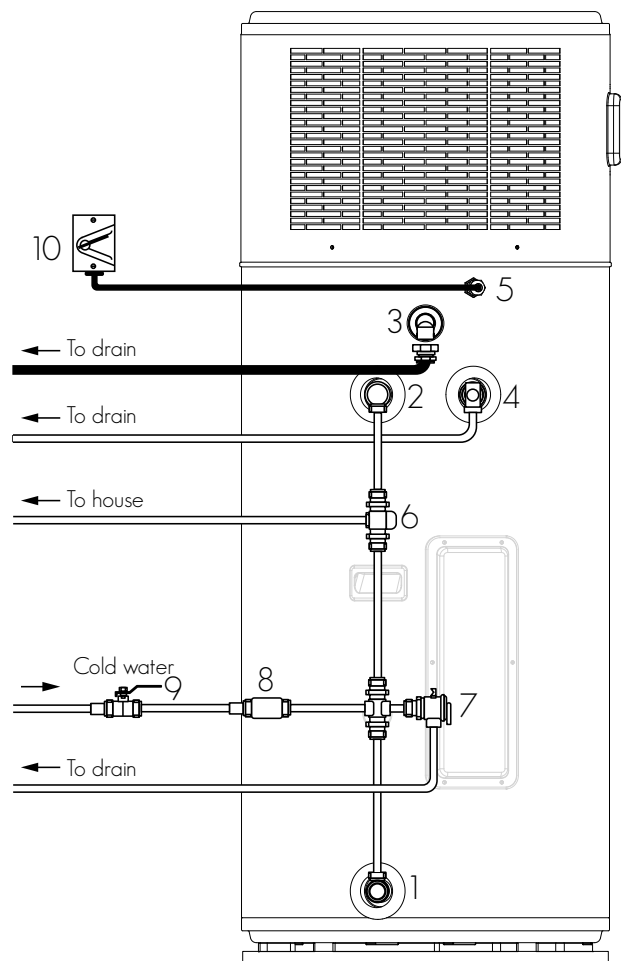

## 5.0 PLUMBING INSTALLATION

### 5.1 PLUMBING CONNECTIONS

#### 5.1.1 Cold water supply outlet

- The cold water supply connection is a G 3/4" female thread.
- The cold water supply should be connected to G 3/4" socket.
- The cold water supply outlet can also act as a drainage point for emptying the system.

#### 5.1.2 Hot water connection

- The hot water supply connection is a G 3/4" female thread.
- The hot water supply should be connected to G 3/4" socket.
- To ensure thermal efficiency all hot water lines and connections must be insulated with a minimum 13mm closed cell insulation.
- All hot water supply parts must be constructed from copper. If using pipe of other material please refer to local authorities for further instructions.

#### 5.1.3 Condensate Drain

- The process of heat extraction from the atmosphere through evaporator coils results in the production of water in the form of condensation. More humid environments will produce higher rates of condensation.
- To collect this water by-product a Condensate Tray is located on top of the water storage tank. Overflow from this tray runs out through the Condensate Drain.
- The system comes with a pre-installed condensate drain connection elbow. Drainage of condensate from elbow to nearest storm water to be done by the collection of condensate into an open dish and drained via copper piping. If not drained properly, the condensate line will attract termites as well produce algae and moss growth.
- The Condensate line should be free of kinks and as the water is gravity fed, should only be running down to ensure the free flow of water.

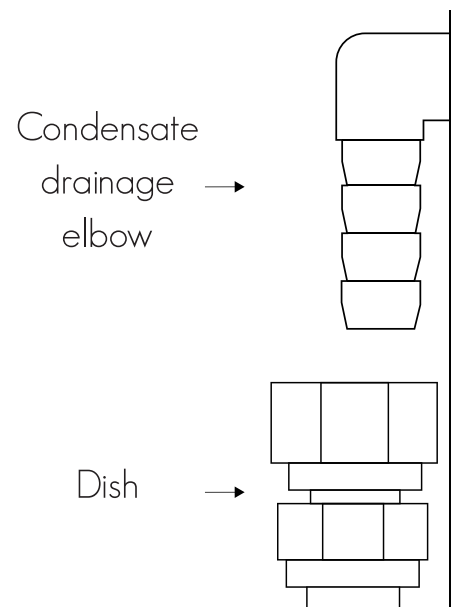

A PVC tube is supplied which can be used to bridge the air gap between the condensate elbow and dishes. The PVC tube can also be used to drain condensate directly from condensate elbow to a storm water drainage point, if copper pipe drainage is not required by local council regulations.



Connecting any line to the condensate line without an air gap will void warranties.

#### 5.1.4 Pressure & Temperature Relief (PTR) Valve

- The system is supplied with a loose PTR valve appropriate to the pressure rating of the water heater tank. If the PTR valve is not present please contact your supplier. The valve Rated capacity: 850kPa; 10kW; Set temperature: 93-99°C.
- The supplied PTR valve must be installed at Point 4 in section 3.2 RAPID X6 Connection Dimensions and Components under the socket marked "RELIEF VALVE".
- The PTR valve must be insulated with a minimum 13mm closed coupled insulation, to minimize heat lost.
- The relief valve must be installed so that the drain line is facing downwards at all times with the discharge point remaining open to the atmosphere.



A discharge pipe connected to the pressure relief device is to be installed in a continuously downward direction and in a frost-free environment. **Do not connect any pressure-relief device to the condensate drain pipe.** The water may drip from the discharge pipe of the pressure-relief device. This pipe must be left open to the atmosphere. The pressure-relief device is to be operated regularly to remove lime deposits and to verify that it is not blocked.

#### 5.1.5 Tempering Valve

- RAPID/X6 systems are automatically programmed to produce hot water in excess of 50°C. As such, in accordance with AS/NZS3500, it is mandatory that a Tempering Valve is installed.
- We recommend a high performance or solar rated tempering valve is used to ensure a more accurate hot water delivery temperature.
- Your old hot water system might not have had a tempering valve installed before and therefore you will notice a change in the temperature of the hot water. This is normal and required under new legislation. Should you have any concerns, please contact your installer.

#### 5.1.6 Expansion Control Valve

- Please observe local requirements with regards to the installation of an ECV (optional in most councils).
- When installing an ECV, ensure that the connecting pipe has a diameter no greater than that of the safety valve.
- Ensure the drain is sized to allow for water runoff, even in incidents where the safety valve has been fully opened.
- The drain outlet must remain open to the atmosphere at all times and must not have a closing function.
- The ECV should be rated at no more than 700kPa.

#### 5.1.7 Pressure Reducing Valve

- This water heater is supplied with a PTR valve rated at 850kPa and is designed for direct connection to mains water supply with a pressure not exceeding this rating.
- Should main pressure fluctuate above this rating, a pressure limiting device (AS1357) should be connected at Point 8 in section 3.2 RAPID X6 Connection Dimensions and Components.

### 5.1.8 Non-return/Isolating Valve

- It is compulsory that a non-returning/isolation valve is installed directly into the cold-water supply line feeding the system. This will allow the hot water system to be isolated from the rest of the homes water supply, making servicing, draining and replacing the unit easy. A hose-set must not be used to connect the system to water supply.
- The non-return/isolation valve can be combined with a PRV valve to form a duo valve.

#### Filling the System:



- Once the Aquatech has been connected in accordance to Section 3.0 and 4.0 of this handbook, the tank can be filled and pressurized.
- Open the non-return valve on the cold-water inlet to begin filling the system with water. At the same time, ensure at least one hot water tap is open inside the property. While the system begins filling with water you will hear air being expelled from the open hot water tap. This is called "bleeding the system" and it ensures that no air pockets remain. Once water begins running out of the hot water tap, the system is completely bled and you can then turn the tap off.
- Always ensure that the tank is completely full before connecting and turning on the electricity supply.

# 6.0 ELECTRICAL CONNECTION



Only qualified electricians may carry out the installations of the Aquatech heat pump to main power in accordance with the following instructions.

## 6.1 ELECTRICAL SCHEMATICS

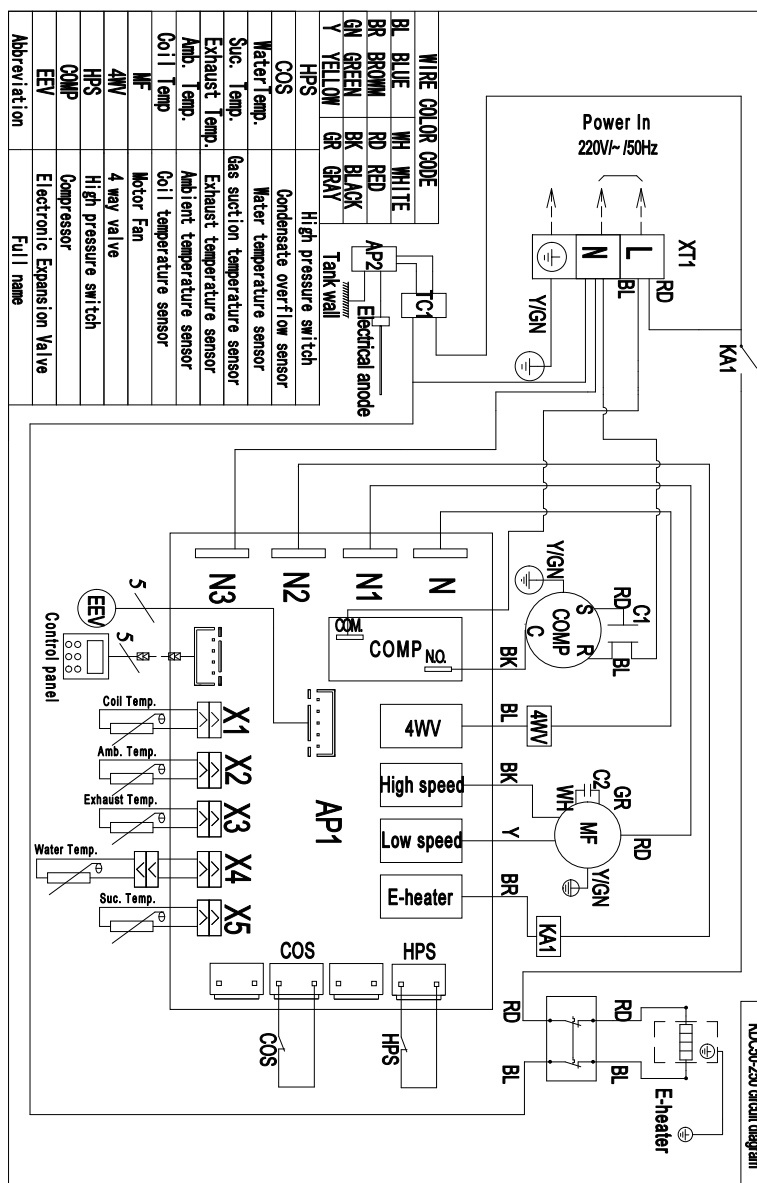

## 6.2 PRE-CONNECTION & REGULATIONS

- Before any work can commence, ensure that the heater is isolated from the power supply at the control panel.
- The RAPID/X6 heat pump is designed for permanent fixed wiring to either a Continuous Tariff (single phase 240V AC supply) or a Shoulder Tariff (single phase 240V AC supply).
- When connecting the unit, electrical work must comply with the local supply authority regulations as well as AS3000.
- The power rating of the unit is set at 10 amps as such the mains power supplying the unit must have a 10 amp minimum circuit breaker fitted.
- To gain access the electrician may remove the four connecting screws and raise the cover upwards off the unit base exposing electrical works (see section 3.2 RAPID X6 Connection Dimensions And Components).
- Note this device is fitted with an over-temperature control cut-out. Under no circumstances must the water heater be in operation without this safety device connected to the circuit. Re-setting and replacement of this device must only be carried out by a qualified electrical contractor.
- (AS/NZS 60335-1 Clause 7.12.2): disconnection must be incorporated in the fixed wiring in accordance with the wiring rules.
- FUSE: 250V, T3.15A

## 6.3 HARDWIRING THE SYSTEM

- The RAPID/X6 system is supplied with a 3 point earthed plug and may be run off a standard power socket or extension cord. Running the unit off the plug should only be temporary (e.g. when an electrician is delayed to your home).
- For continued long term operation, the system must be hard wired into an isolated 10 amp circuit.
- A qualified electrician should remove the units plug and utilize the power supply cord to wire the system into a junction box.
- The junction box must be rated for outdoor use and should be fitted with an isolating switch as shown in the diagram to the right.

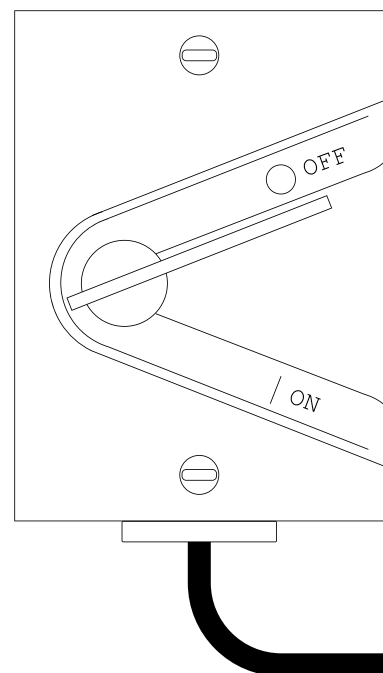

Depending on the installation address, the Aquatech must be connected to either a Continuous or Shoulder Tariff power supply. Please refer to section 2.4 for further information.



If the supply cord is damaged, it must be replaced by either the manufacturer, a service agent or similarly qualified person in order to avoid a hazard.



This appliance shall be installed in accordance with National wiring regulations AS.3000.

## 7.0 COMMISSIONING THE SYSTEM

### 7.1 PRE-START PROCEDURES & CHECKS

- Once both the electrical and plumbing connections have been completed by qualified trades person, the system is now ready for operation.
- Before turning the system on it is essential that you ensure the heat pump storage tank is full and the unit thoroughly flushed.
- Air pockets must be bled from the system via a hot water tap. Do not use the PTR valve alone to bleed the system.
- Ensure the device is resting on a smooth flat concrete plinth and that a condensate drain is installed from the condensate port to an appropriate drainage point.
- Ensure that your plumber has insulated with high temperature closed cell insulation to prevent heat loss.
- Ensure that air can flow freely around the intake vents.

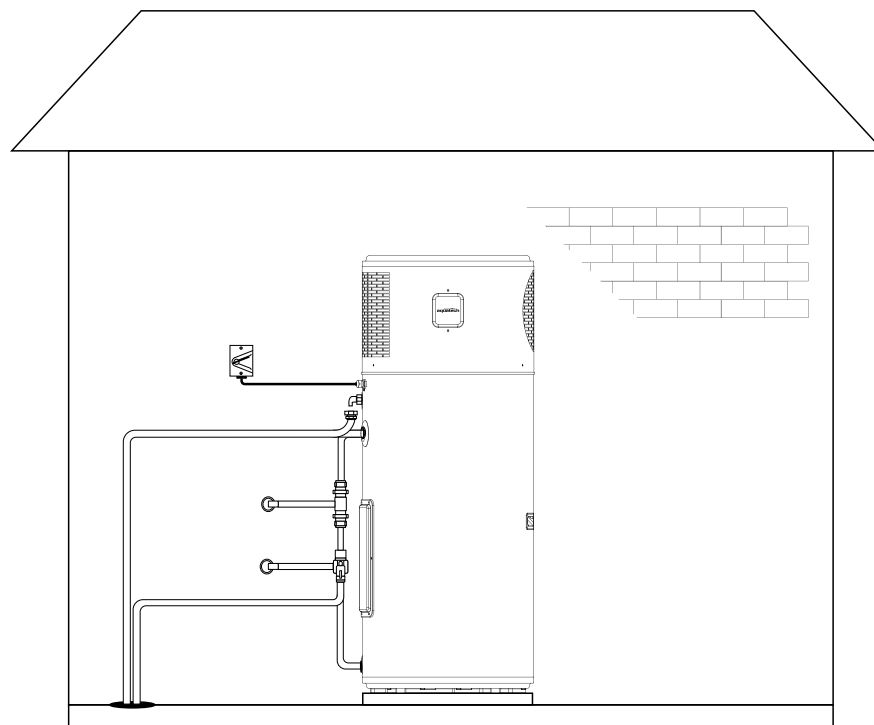

This appliance is not intended for use by persons (including children) with reduced physical sensory or mental capabilities, or lack of experience and knowledge, unless they have been given supervision or instruction concerning use of the appliance by a person responsible for their safety. Children should be supervised to ensure that they do not play with the appliance. The appliance shall be installed in accordance with national wiring regulations.



## INSTALLATION CHECKLIST

- The RAPID/X6 system is level.
- The RAPID/X6 system is installed on a concrete plinth or stable structure capable of sustaining weights in excess of 315kg.
- A minimum distance of 300mm is present above the RAPID/X6 system, to allow the lid to be removed for maintenance (see section 2.3 Air Flow).
- A minimum distance of 600mm is present on the fan discharge side and 150mm on the air in take sides of the system for airflow (see section 2.3 Air Flow).
- A minimum distance of 150mm is present between the exterior of the tank and wall for air circulation and servicing (see section 2.3 Air Flow).
- The condensate drainage elbow has only been hand tightened (see Section 4.0 Plumbing Installation).
- The condensate drainage elbow is free flowing (i.e. gravity fed) and not directly connected to the PTR or any other line (see section 4.0 Plumbing Installation).
- The unit is connected to either a Continuous 24 hour supply or a Shoulder Tariff Minimum 16 hour supply. (not connected to the Off-peak 8-10 hour supply).
- The plumber has explained the purpose of the tempering valve.

Once the system has been installed, the installing plumber should sign below to ensure that all procedures have been complied to otherwise warranties may be voided.

Installer's Full Name:

Date:

---

---

Installer's Signature:

---

Once you have carried out all these checks, you are ready to  
switch on your RAPID/X6.

## 8.0 OPERATION PANEL INSTRUCTIONS

### KEY FACTORS

- Aquatech recommends using the in-built timer functions unless your household requires a large demand of hot water. Please be aware of incoming water temperature seasonal changes, tariffs and usage patterns when customising timer periods.
- Aquatech systems are pre-set at 60°C storage temperature to ensure the control of Legionella bacteria.
- Temperature differential setting of 5°C (i.e. heap pump heating cycles begins at 55°C water temperature).

ANY ISSUES OR QUERIES? Please contact Aquatech directly on TOLL-FREE [1300 769 904](tel:1300769904)

### 8.1 ACCESSING THE DISPLAY PANEL

A stainless-steel display cover protects the display screen from any potential damage. To access the display panel:

1. Undo the hand screws located at the top and bottom of the display cover by turning them clockwise. Place the hand screws somewhere safely.
2. Slowly remove the display cover and place somewhere safe.

To reattach the screen cover:

1. Place the display cover over the display screen, ensuring the hand screw holes are aligned.
2. Replace the hand screws and using your hands only, tight the hand screws by rotating clockwise. Ensure that a seal is formed from the display cover over the display panel.

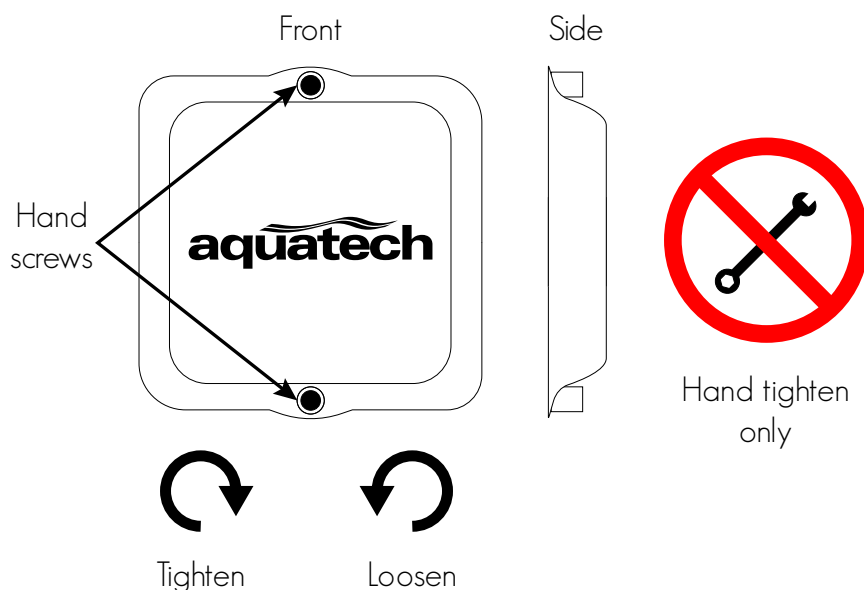

Always ensure that the screen panel has been replaced after accessing the control screen. If the screen panel has not been replaced, the screen may become damaged from the elements.

## 8.2 CONTROL INTERFACE







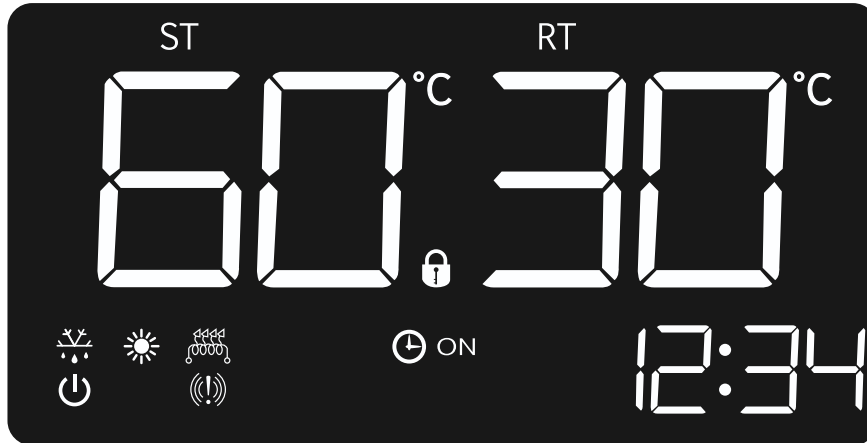

Located on the front of the RAPID/X6 is the unit interface. It houses all the controls and displays necessary to operate your new RAPID/X6 system.



### 8.3 INTERFACE ICONS

The legend below indicates all components referred to in this manual.

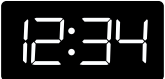

SYMBOL	MEANING
	Screen is locked. Press any button to unlock.
	System is on.
	System is in heating mode.
	System is in defrost mode.
	Alarm representing a fault. Please take note of the error code beginning with "E" before contacting us directly.
	Electric heater is active.
	Timers are active.
	Internal system clock.
	Set water temperature.
	Current water temperature.

## 8.4 UNLOCKING & TURNING THE SYSTEM ON

---

1. Press the ON/OFF button once to unlock and illuminate the screen further.



When the lock symbol is present, pressing any button once will unlock the controller and further illuminate the screen.

---

2. Press and hold the ON/OFF button for 3 seconds. The sun symbol will flash before turning constant, signifying that the system starting to heat.



## 8.5 SETTING THE TIMERS

Using timers is recommended for the following reasons:

1. Heat pumps work considerably more efficiently during daylight hours when ambient air temperatures are at their highest.
2. Having the RAPID/X6 system heat during the day is less likely to disturb anyone.
3. The in-built timers can be used to fully utilize a Solar PV system.

The factors to consider when using timers are:

1. **Tariffs** - certain tariffs will not coincide with the default timer periods and therefore the system may not have enough time to recover.
2. **Hot water usage** - Be aware of your peak usage and recovery times.
3. **Temperature & Climates** - Ensure you allow enough time for the unit to heat in varying temperatures and humidity.

---

1. Press and hold the CLOCK button for 4 seconds. The "clock" and "1" symbols will illuminate and the "ON" symbol will flash.



---

2. Press the ON/OFF button once to confirm timer periods. The clock symbol will now remain constant signifying the system is using the timers.



The factory default for the in-built timer period is 09:00-18:00.

RAPID/X6 systems will run using the timers when the following conditions are met:

1. The water temperature as shown on the display screen is below 55°C.
2. The time displayed on the screen is within the period designated by the set timers (factory default periods are 09:00-18:00. i



For further information about setting timers, please visit the Aquatech website or contact Aquatech directly.

## 8.6 SETTING THE CLOCK

The correct time is necessary for the RAPID/X6 to operate using the timers. Please note that the time is displayed in a 24-hour format.

1. Press the CLOCK button to begin setting the time. The hour value will begin flashing.



2. Press either the UP or DOWN button to adjust the flashing hour value (example hour set to "14").

When ready, press the CLOCK button to toggle to the minute value.



3. Press either the UP or DOWN button to adjust the flashing minute value (example minute set to "30").

When ready, press the CLOCK button to finish setting the clock.



If the time is inside of the timer periods on TIMER mode, the system will display "ON " next to the clock. If the time is outside of the timer periods on TIMER mode, the system will display "OFF " next to the clock.



For example (using factory default timers):

Time = 09:00 →  
Time = 18:00 →



## 8.7 ERROR HANDLING

RAPID/X6 systems will display an error code when a fault has occurred. The error message will show where the time is usually displayed as well as the error symbol. Please note the error code before contacting Aquatech directly.

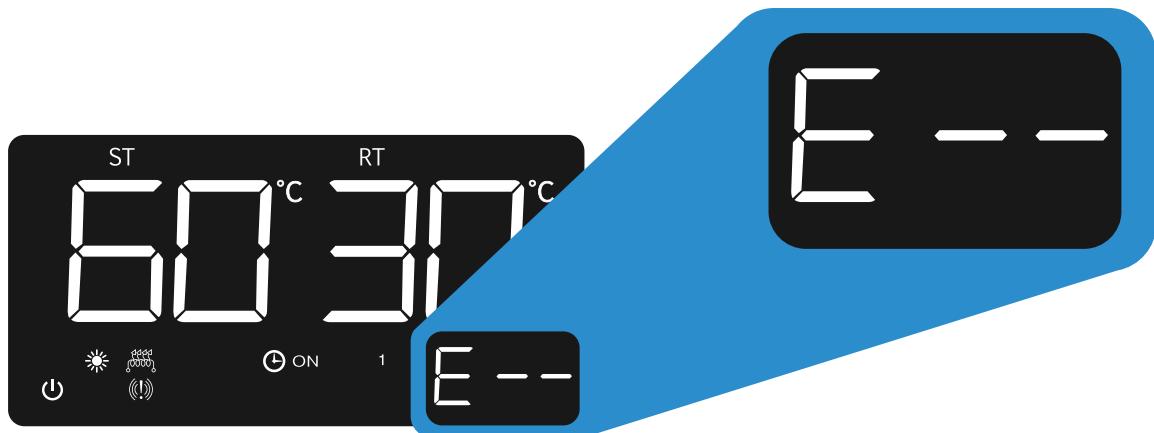

Depending on the error code, the system will automatically continue to heat using the electric element. The electric element symbol will display if this is the case.



## 9.0 TROUBLE SHOOTING

### No hot water

Possible causes	Checks	Solution
System has no power and cannot heat	Check to see if the control screen is illuminated.	If the screen is blank, check the supply power switch is turned on and that all home fuses are up. If all fuses are down, contact your electrician or energy provider to ensure there is power going to the system.
Issue with the home's tempering valve.	Check the RT temperature on the control screen.	If the RT temperature is reading higher than the temperature at your taps, contact your installing plumber to service/replace the home's tempering valve.
Issues with the system's temperature sensor.	Check the RT temperature on the screen.	If the RT temperature is showing above 70°C or displaying two lines, turn the power off to the system for 30 minutes to reset. If the error continues when power is turned back on contact us on 1300 769 904 to arrange an onsite service.
Issue with the system's controller settings.	Check the controller is showing Power on button.	Press and hold the UP button and then M button for 5 seconds to perform a quick heat. The system will engage the element to heat the temperature up to 60°C. If the issue persists contact us on 1300 769 904 to arrange an onsite service.

### Running out of hot water

Possible causes	Checks	Solution
High flow shower heads installed	Call plumber to check home's shower heads.	Plumber can replace shower heads or install water flow valves to reduce your hot water usage
System is on an off-peak tariff	Check with energy provider that the system is not on an off-peak tariff	Switch to a continuous power supply tariff.
System timers are set with too small a recovery period.	Check the control for clock symbol is illuminated.	Contact us on 1300 769 904.
System is in error mode	Check controller to see if any error code is displayed.	Note down code and contact us on 1300 769 904.

If the above issues are resolved and you are still running out of hot water, contact us on 1300 769 904 during office hours and a technician can assist.

## Condensate and/or PTR Leaking

Owners can expect at least 5 -10L of water to be drained daily from condensate and relief valves during the systems heating. If more than a bucket a day of water is being drained contact your installing plumber to check all relief valves.

## Adjusting the hot water temperature

All hot water systems must be installed with a tempering valve that limits the water temperature at showers and bath outlets to a maximum of 50°C. Adjusting the systems thermostat will not result in hotter water at these outlets. If you require a higher temperature at your kitchen or laundry taps, please discuss with your installing plumber about possible solutions.

## Low hot water pressure

The hot water pressure available at your taps is dependent on your homes incoming water mains pressure as well as any pressure restricting or tempering valves, your plumber may have installed. The RAPID/X6 does not control or limit the hot water pressure delivery in anyway. If the pressure at your hot water taps is significantly reduced compared to your cold-water taps, contact your installing plumber.

## What maintenance does the RAPID/X6 need?

The heat pump water heater is designed to eliminate system maintenance other than that detailed in this Owner's Manual. The PTR valve and ECV should be checked for adequate performance or replaced at intervals not exceeding 5 years or less if local regulations apply. The lever on these relief valves should be pulled to operate at least once every 6 months. Personally inspecting or servicing any other part of the system is not recommended.

Every 5 years you should contact the local service agent or licensed plumber to replace all safety valves and Magnesium Anodes to ensure continued system life and operational safety. In locations where the potable water has a TDS greater than 600 ppm, this service is recommended every 3 years.

## What safety features does the RAPID/X6 have?

If installed correctly, the RAPID/X6 system has the following safety features:

- An over-temperature energy cut-out thermostat.
- A Pressure & Temperature Relief (PTR) valve and Expansion Control Valve (ECV).
- A 3 minutes delay from powering the system to prevents any damage from electrical surges

## What should I do to the RAPID/X6 if I go away on holiday?

Leave the system as per normal. The RAPID/X6 has built in safety features which will prevent Legionnaires' disease from occurring while you are away. The amount of electricity used by the system while there is no hot water being used is minimal.



If the hot water system is not used for two weeks or more a quantity of highly flammable hydrogen gas may accumulate in the water heater. To dissipate this gas safely, it is recommended that a hot tap be turned on for several minutes or until discharge of gas ceases, use a sink, basin, bath outlet, but not a dishwasher, clothes washer or other appliance. During this procedure, there must be no smoking, open flame or any electrical appliance operating nearby. If hydrogen is discharged through the tap, it will probably make an unusual sound as with air escaping

### 5 YEAR SYSTEM + 1 YEAR LABOUR WARRANTY

Aquatech Solar Technologies Pty. Ltd. warrants the Aquatech RAPID/X6 will be free from minor defects and major failures for a period of 5 years from the date of system installation. When proof of installation date is not provided, the start date of the warranty will commence from the system date of manufacture determined by the systems unique serial identifier.

This warranty covers only Aquatech - RAPID/X6 systems sold and installed in Australia with serial number begins with AQU6.

### MINOR DEFECTS

A minor defect is determined by an approved service agent or the Aquatech Solar Technologies Pty. Ltd. service department and is classified as a repairable non-critical failure of a system part or parts. Owners can claim reimbursement for the following costs associated with a minor defect:

All parts under section 1.2 SCHEMATIC RAPID/X6 will be supplied free of charge for a period of 5 Years from the date of install or manufacture.

All onsite labour costs directly associated with fitting or replacing of listed parts by Aquatech Solar Technologies Pty. Ltd. approved service agent or Aquatech Solar Technologies Pty. Ltd. service department. Will be covered for 1 Years from the date of install when proof of purchase is provided or date of manufacture. when proof of purchase is not supplied.

### MAKING A MINOR DEFECTS CLAIM

The following steps should be taken when making a warranty claim with Aquatech Solar Technologies Pty. Ltd:

1. Owners experiencing issues with their system are to contact Aquatech Solar Technologies Pty. Ltd. service department directly on 1300 769 904 during operating hours.
2. If your issue can not be dealt with over the phone, owners will be supplied with details of service agent in their area.
3. Owners will need to contact and deal with service agents directly in relation to the booking in and payments of works related to the service or repair of their system.
4. Owners can claim reimbursement for costs of parts covered under schematic 1.2 SCHEMATIC RAPID/X6 and for onsite labour charges covered if completed by an approved Service Agent or Aquatech Solar Technologies Pty. Ltd. service department. To claim reimbursement of costs by completing an Minor Online Claim Document. Owners will need to provide the following documents when making a claim:
  - Proof of purchase/installation to validate system age, if not supplied system age will be determined from date of manufacture.
  - Copy of invoice from an Aquatech Solar Technologies Pty. Ltd. approved service agent or Aquatech Solar Technologies Pty. Ltd. service department.
5. All Service Claim Submissions will be processed and reimbursement on validated claims paid into owner nominated account within 7 business days.

## MAJOR FAILURES

A major failure is classed as a non-repairable critical failure making the system not fit for use defined by either of the following two parameters:

1. The System storage tank will be free from leaks under operating conditions where inlet water pressure does not at any time exceed the rated input of 500kPa and has been proven as being non-corrosive by meeting the following conditions: a PH range of not less than 6 and not more than 8 and a total chloride measure of not more than 250mg per litre of water.
2. The System will provide sufficient performance as to guarantee a heating capacity equal to meet a medium load demand for the climate zone it has been installed in, as outlined in AS/NZS 4692.1:2005., when connected to a continuous power supply.

A major failure can only be validated by an Aquatech approved service agent or plumber, or by the Aquatech Solar Technologies Pty. Ltd. service department. If a major failure is validated an approved agent will need to complete a Major Failure System Report (contact Aquatech directly for a copy). Owners will be required to support their warranty claim by providing a Major Failure System Report document which is to be created by one of the approved agents.

## MAKING A MAJOR FAILURE CLAIM

The following steps should be undertaken for making a major failure claim:

1. Owners experiencing issues with their system are to contact Aquatech Solar Technologies Pty. Ltd. service department directly on 1300 769 904 during operating hours.
2. If your issue cannot be dealt with over the phone, owners will be supplied with details of service agent in their area.
3. Owners will need to contact and deal with service agents directly in relation to the booking in and payments of works related to the service or repair of their system.
4. If an attending Aquatech approved service agent determines that the system has a non-repairable fault resulting in a Major Failure they will generate a Major Failure System Report and submit to owner along with a copy of their invoice for attending the job.
5. Owners must submit the following documents in order to validate a Major Failure Claim:
  - Major Failure System Report completed by approved Aquatech Service Agent
  - An original purchase invoices or installation invoice to prove ownership and to determine that the system has not been relocated or altered from the original install.
6. A Major Failure can only be claimed for a period of 5 Years from the date of system install. Owners who can support their claim of a Major Failure within 5 Years of the date of install, will be supplied with a free system of equal or similar tank and heating capacity, depending on models available at time of claim. Owners will be entitled to any and all Government subsidies that maybe available to them at the time of the supply of a free system., any claims to such subsidies will be the responsibility of the owner.

The replacement system will be made available for collection from the closet Aquatech Warehouse or distributor to the owner's address. Any associated cost for shipping and or delivery of the free replacement system from said warehouse and or distributor will be at the owner's expense and

therefore are not covered under the warranty terms and conditions. This includes any costs required to locate the system into the installation location.

The owner is responsible for any and all costs associated with the installation of the replacement system by a licensed tradesman of their choosing.

If a free replacement system is supplied in the event of a Major Failure Claim, any and all warranties will be determined based on the date of the original system as prescribed in the Major Failure System Report and not the date of the replacement system. For purpose of future warranty claims the replacement system will be prescribed the same serial number as the original system. All warranty claims made against the replacement system will be treated without prejudice up to 5 Years from the date of the original system installation determined by either proof of purchase, or Major Failure System Report, and failing the supply of these documents the original date of manufacture.

## WARRANTY EXCLUSIONS

This warranty does not cover any costs associated with the failure or damage of the Aquatech RAPID/X6 system under the following circumstances:

- Any failure of listed parts or complete system where the systems has not been installed in compliance with installation instruction as outlined in the Aquatech RAPID/X6 Installation and User Guide Document and all statutory and local requirements of the state in which the water heater is installed.
- Any damage to system components that are aesthetic in nature and do not impact on the system performance or ability to provide hot water. These include but are not limited to: corrosion that does not effect structural integrity (e.g. tea staining), dents or other visual defects.
- Damage to parts due to miss handling of system in transport or during installation.
- Accidental damage including: Acts of God, misuse use of system, repairs to system not completed by approved Aquatech Solar Technologies Pty. Ltd. service agent. or Aquatech Solar Technologies Pty. Ltd. service department.
- Any failure of parts where electrical supply currents and voltages have exceeded the specified 240V supply by more than a 10% variance.
- Any failure of parts due to noise in the electrical supply.
- Any failure of parts not outlined in section 1.2 SCHEMATIC AQUATECH RAPID/X6. of this document including any parts supplied and installed during the installation of system.
- Any associated plumbing parts including the PTR Valve, which is covered by third party suppliers, have a two-year warranty (parts warranty only).
- Failure of the Aquatech RAPID/X6 system or any associated parts as a result of damaged from insects or animals. • Installations where the pipe work has been connected directly to the condensate drain elbow, without a sufficient air gap.
- Subject to any statutory provisions to the contrary, this warranty excludes any and all claims for damage to furniture, carpets, walls, foundations or any other consequential loss either directly or indirectly due to leakage from the system or due to leakage from fittings and/or pipe work of metal, plastic or other materials caused by water temperature, workmanship or other modes of failure.

## NON-RESIDENTIAL WARRANTY

Where the Aquatech RAPID/X6 has been installed in any capacity not related to the supply of potable hot water at a temperature not in excess of 70°C, the installation will be deemed as non-residential and all warranties are void.

## COMMERCIAL WARRANTY

The Aquatech RAPID/X6 has been rated to meet a medium load delivery per AS/NZS 4692.1:2005 across all five climate zones. Where the average daily hot water demand made on a single Aquatech RAPID/X6 system is shown to be 150% or above medium load demand for the climate zone in which it has been installed as outlined in AS/NZS 4692.1:2005, the system will be classed as a commercial installation and therefore void all warranties.

## INSTALLATION ON A CIRCULATING RING

The Aquatech RAPID/X6 is designed to operate with an independent cold-water feed. Installing the system on a circulating feed, where hot water will be re-entering the system, will void all warranties. This includes manifolding multiple systems as a single installation.

## SUPPLIED PTR VAVLE

The supplied PTR valve has a warranty period of 2 years from the date of installation as per AVG's warranty terms and conditions.

## WARRANTY DETAILS

### CUSTOMER'S DETAILS

Name: \_\_\_\_\_  
Address: \_\_\_\_\_  
Phone Number: \_\_\_\_\_  
Email Address: \_\_\_\_\_

### SYSTEM DETAILS

Model: RAPID/X6  
Serial Number: \_\_\_\_\_  
Installation Date: \_\_\_\_\_ / \_\_\_\_\_ / \_\_\_\_\_  
Scope of works: 

<input type="checkbox"/>	New home	<input type="checkbox"/>	Replacement HWS
--------------------------	----------	--------------------------	-----------------

### INSTALLER'S DETAILS

Name: \_\_\_\_\_  
Address: \_\_\_\_\_  
Phone Number: \_\_\_\_\_  
Email Address: \_\_\_\_\_  
License Number: \_\_\_\_\_







[info@aquatechheatpumps.com.au](mailto:info@aquatechheatpumps.com.au)  
[www.aquatechheatpumps.com.au](http://www.aquatechheatpumps.com.au)

TOLL-FREE 1 300 769 904